

# 2 SERIES NON-IC / IC / REMODEL

## RECESSED LED DOWNLIGHT HOUSINGS AND TRIMS

### INSTALLATION

Before beginning any DOWNLIGHT installation, disconnect electrical power at main switch or circuit breaker.

#### A. CAUTION

To reduce the risk of fire, electric shock, and potential damage to recessed housing assembly when electrical power is re-connected, DO NOT ATTEMPT TO CONNECT the following on branch circuit serving recessed downlight assembly:

- Motors
- Power tools
- Extension cords
- Appliances or similar electronics

Housings to be mounted in ceiling / plenum conditions *where ambient temperatures do not exceed 40°C unless otherwise noted as 35°C on specification sheets.*

Ensure AC input voltage is protected against surges & load shifts prior to power supply input.

#### B. SAFETY INSTRUCTIONS

1. Read installation instructions completely before attempting installation.
2. Failure to follow instructions may result in improper installation and void warranty.
3. Contact Lucifer Lighting Company with any questions or concerns before beginning any installation.
4. Ensure qualified electrician will perform all electrical procedures.
5. Disconnect electrical power circuit before attempting to install recessed downlight housing or trim, or if adding to or changing configuration of downlight housing or trim assembly.

6. Install/mount recessed downlight housing on structurally sound surface.
7. Recessed downlight housings must be installed in dry or damp locations only.
8. **IC housing allows:**  
**Direct contact with** polycell spray-in foam insulation having max R-Value of 60 allowed on all sides and top of housing.
9. **Non-IC housing requires:**  
**Minimum 1/2" (13mm)** setback from combustible materials on all sides and top of housing.  
**Minimum 3" (76mm)** setback from insulation material having max R-value of 30 on all sides and top of housing.  
**Minimum 6" (152mm)** from polycell spray-in foam insulation having max R-Value of 60 on all sides and top of housing.
10. **Consult factory for spacing requirements for any installations exceeding R-Value of 60.**

10. **Remodel fixture requires:**

**Minimum 6.63" (168mm) radius** setback from combustible and non-combustible materials from any one fixture centerline.

**Minimum 2.75" (70mm) clearance** from top of trim, **4" (102mm)** in Gemini applications.

**Minimum 6.75" (172mm)** between any two fixture centerlines, as in Gemini applications.

**Minimum 3" (76mm) clearance** from surfaces of power supply / junction box, if not situated within above noted radius from fixture centerline and **minimum 6" (153mm)** clearance between power supplies / junction boxes in Gemini applications.

**Minimum additional 3" (76mm) setback** from insulation material with max R-Value 30 from any surface of downlight fixture assembly, **6" (153mm)** if two fixtures are installed within a 12" on center spacing.

**Minimum additional 6" (152mm) setback** from polycell spray foam insulation with max R-Value 60 from any surface of downlight fixture assembly, **12" (305mm)** if two fixtures are installed within a 12" on center spacing.

**Consult factory for spacing requirements for any installations exceeding R-Value of 60.**

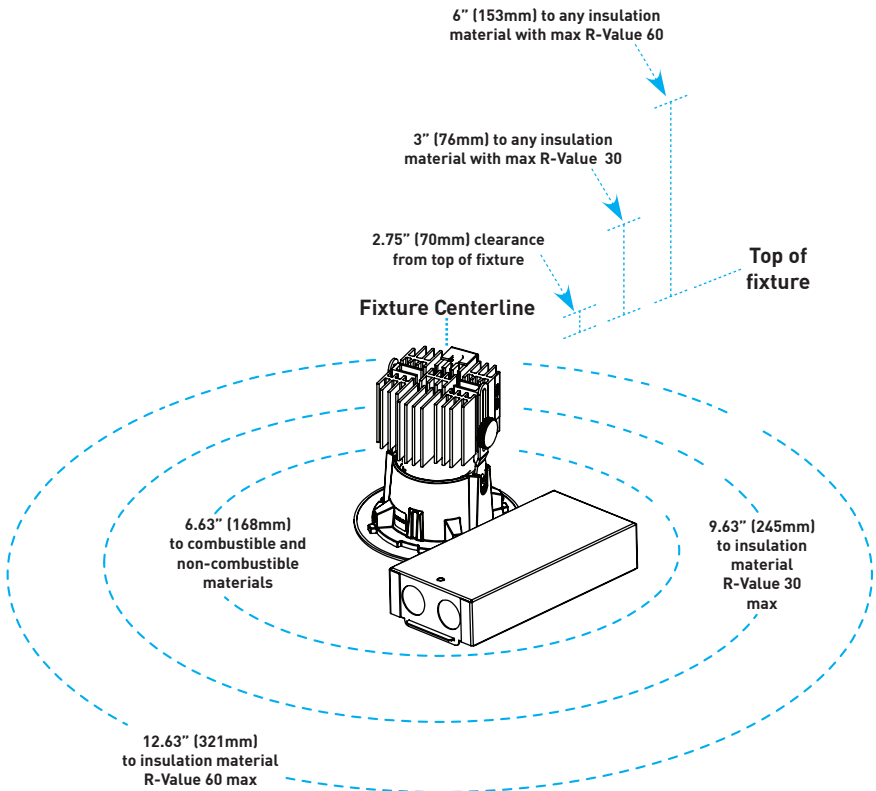

11. Do not attempt this installation if you do not understand these instructions.

## C. HOUSING INSTALLATION

### 1. KEY FIXTURE COMPONENTS

Become familiar with housing, hanger bar assemblies and housing collar.

Housings provide access through housing aperture for servicing from below.

Cover plate **"Fig.1"** provides access to wiring connections prior to installation of ceiling substrate. Low flux cover plate is removed by leveraging side tabs to pop off. High flux cover plate is removed by loosening screws.

**Note:** Housing lid is not removable in the field.

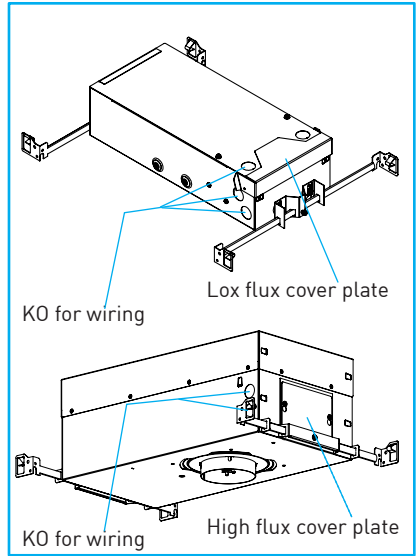

Fig.1

Remodel driver assembly features detached j-box with integral splice compartment and 6" flexible conduit with connector for joining with trim **"Fig.2"**. For remodel installations, see section "F. REMODEL APPLICATION".

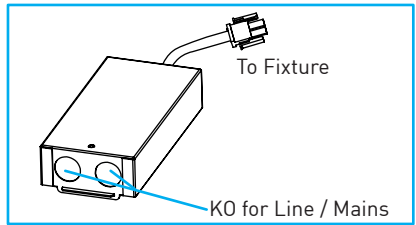

Fig.2

Remote driver assembly features integral driver with separate primary and secondary wiring compartments **"Fig.3"**.

**Important:** Remote driver must be mounted in accessible and serviceable area.

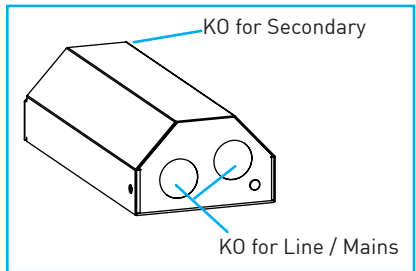

Fig.3

## 2. HANGER BAR ASSEMBLIES

**Note:** For remodel installations where traditional housing is not used, see section "F. REMODEL APPLICATION".

Hanger bars extend from 14" to 24" and mount to short axis of high flux housing and long or short axis of low flux housing. To install hanger bars on housing, slide mating halves together, joining through mounting bracket on housing sides. Secure position with central locking screw "Fig.4" "Fig.5".

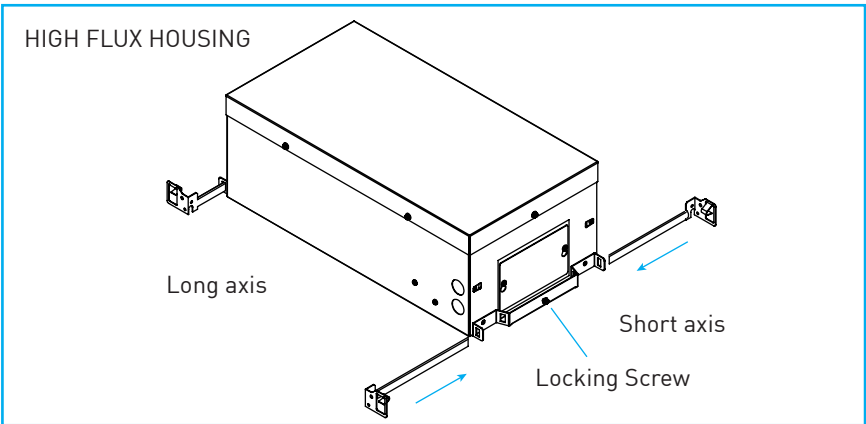

Fig.4

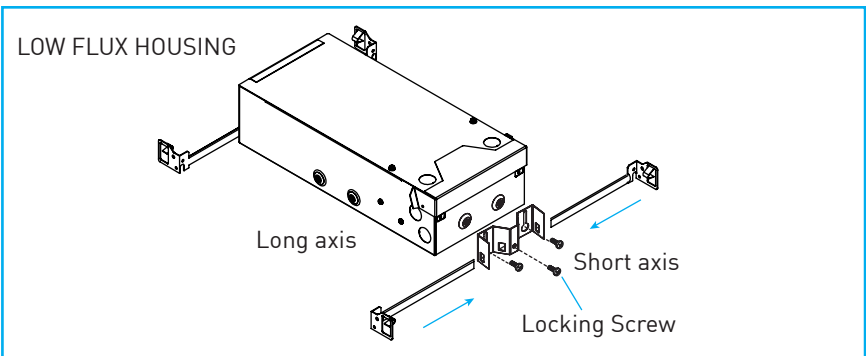

Fig.5

Bottom side of low-flux hanger bar mounting bracket should be flush with underside of housing. If adjustment is required, housing depth may be adjusted using guide on brackets "Fig.6".

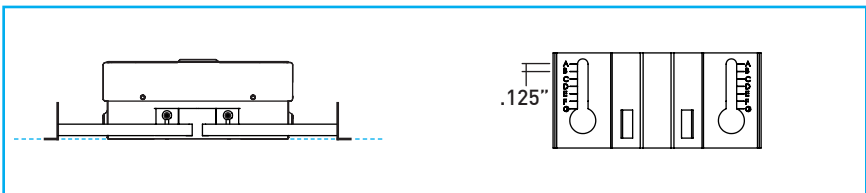

Fig.6

### 3. HOUSING COLLAR

Housing outfitted with one of four different adjustable collars "**Fig.7**", preset at factory to low-end of specified ceiling thickness. For in-field adjustment, loosen two opposing **silver** screws using  $9/64$ " Allen wrench and raise/ lower collar to desired position. Retighten Allen screws to secure positioning "**Fig.8**".

**Note:** Do not loosen or tighten two button-head black screws for standard adjustment. These screws are only removed if changing to different collar.

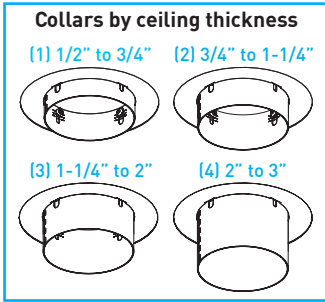

Fig.7

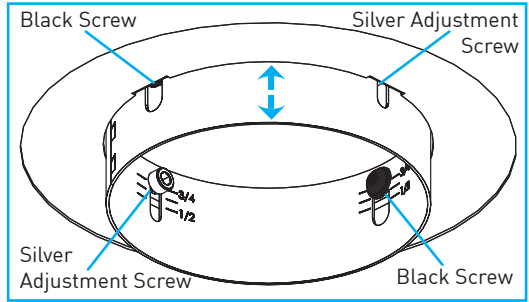

Fig.8

#### 4. MOUNT HOUSING

Follow steps to ensure successful installation. For remodel installations, see section "F. REMODEL APPLICATION".

##### General Housing Mounting Notes:

Recessed downlight housings installed in accessible and non-accessible ceilings shall be supported from the structural members of the building.

Determine specified fixture location. With hanger bars properly affixed to housing (see Section C.2), secure hanger bars to selected framing member.

##### Wood or Metal Studs:

Position reference tab of hanger bar foot to underside of stud **"Fig.9"**. If wood stud, use integral nailing tab and suitable customer-supplied nails or screws to secure. If metal stud, use suitable customer-supplied screws **"Fig.10"**.

**Note:** Must use two nails or screws at each of four hanger bar feet.

##### T-Bar Frame:

Slide hanger bar over appropriately supported T-bar frame. Lock in place as required **"Fig.11"**.

**Note:** See Section "E. CEILING SUBSTRATE AND FINISH OUT" for additional instructions regarding installation of ceiling tiles.

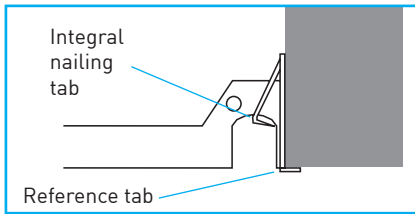

Fig.9

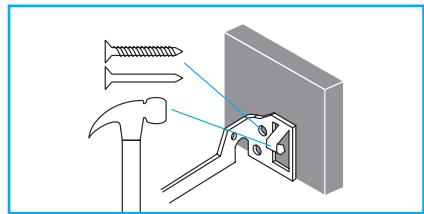

Fig.10

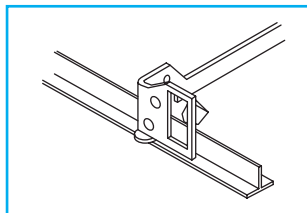

Fig.11

Verify correct housing aperture position using laser or string line, referencing edges of housing **"Fig.12"**.

Tighten hanger bar locking screw to set lateral movement, and ensure all mounting screws are securely tightened (see Section C.2).

**Important:** Collar must not protrude beyond ceiling plane **"Fig.13"**.

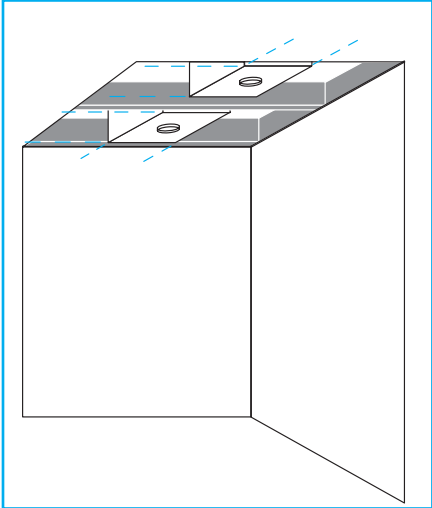

Fig.12

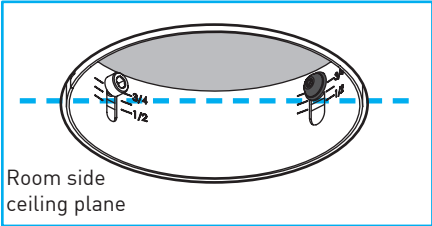

Fig.13

## D. WIRING

### 1. GENERAL WIRING NOTES

**Note:** Consult Safety Instructions in Section "B. SAFETY INSTRUCTIONS" prior to commencing wiring or servicing.

The housing assembly should be installed by a registered electrician and shall comply with National Electric Code (NEC) and local codes and ordinances .

The installer is responsible for furnishing proper electrical equipment and materials for the installations of the housings as intended by these installation instructions.

Install wiring in a manner to permit access to components and splice connections which may require future service. **14" (356mm) minimum customer-furnished feed wires** must be supplied within housing to accommodate future servicing.

Metal conduit shall be used if required by applicable codes. Must use 90°C minimum supply wire only.

No part of the secondary circuit shall be grounded.

For systems that will be dimmed, consult controls manufacturer to verify control compatibility and for proper installation procedures and parameters.

### 2. WIRE HOUSING - UL 1598 INSTALLATIONS ONLY

Gain access to wiring compartment. Low flux cover plate is removed by leveraging side tabs to pop off. High flux cover plate is removed by loosening screws "**Fig.14**".

Feed structured building wires through knockout, secure to corresponding connector "**Fig.15**" and tighten strain relief.

**Quick connectors** provided for line / mains voltage connection: black (hot), white (common) and green (ground) "**Fig.15**".

**Note:** Consult diagrams in Section J, wiring housing in accordance with the applicable driver type and proper selection of control voltage wires. Supplied internal wiring is 18-gauge with 600V-rated insulation.

**Note:** Ensure wires are firmly secured and not tangled prior to moving to the next step.

Push all wires into housing and reinstall cover plate, ensuring that no wires are pinched by cover.

**Important:** Confirm that housing is still in the preferred position.

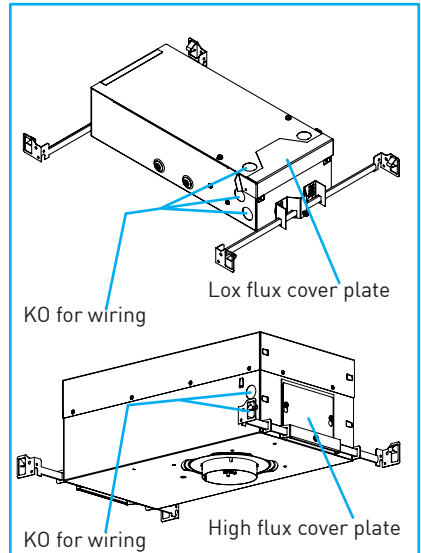

Fig.14

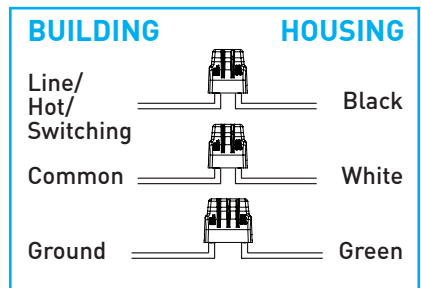

Fig.15



### 3. WIRE REMOTE POWER SUPPLY - UL 1598 INSTALLATIONS ONLY

Determine preferred mounting location, verifying fixture falls within maximum allowable wiring distance **"Fig.16"**.

Run adequately sized plenum rated two-pair wire between remote driver and housing or remodel fixture location, following installation guidelines for terminating as needed.

**Note:** Secondary wiring is polarized (+/-) and must be terminated correctly at both ends for proper operation. It is recommended to use Red (+) and Black (-) wires to avoid confusion. No part of the secondary circuit shall be grounded.

*Ensure proper polarity is observed as reversed polarity may damage the unit and may void the warranty.*

Access splice compartment by removing retaining screws, then tilting cover slightly back and away from base **"Fig.17"**.

Mount transformer back plate assembly to suitable substrate using customer-supplied screws **"Fig.18"**.

Insert line voltage wiring / conduit into line side of splice compartment and secondary voltage wiring / conduit into secondary side of splice compartment, utilizing appropriate strain relief or connector.

**Note:** Consult wiring diagrams in Section "K. WIRING DIAGRAMS" for applicable driver type.

Join structured building wires to corresponding driver wires with suitable customer-supplied wire connecting device.

Push all wires and wire connections into splice compartment and reinstall splice compartment cover by aligning tab with slot, ensuring no wires are pinched by cover. Install retaining screws.

#### Lutron Drivers: "L23", "LH1" & "LP1"

AWG Value	18	16	14	12
Distance (m)	4.5	7.5	12	18
Distance (ft)	15	25	40	60

#### Philips Drivers: "TR2", "AN4" & LN2"

AWG Value	20	18	16	14	12
Distance (m)	14	22	34	55	87
Distance (ft)	45	71	113	180	285

#### eldoLED Drivers: "EA2", "LA2", "ED1" & "LD1"

AWG Value	20	19	18	17	16
Distance (m)	14	18	22	28	36
Distance (ft)	46	59	72	92	118

Fig.16

Min. 8" feed wires in splice compartment

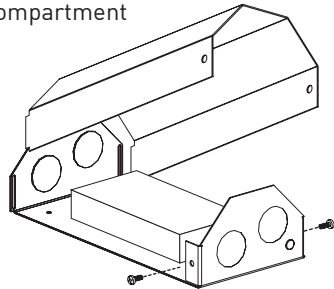

Fig.17

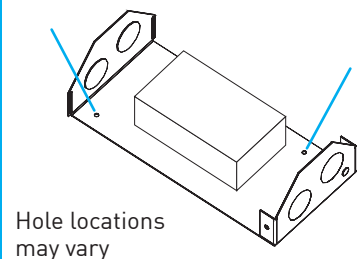

Fig.18

#### 4. WIRE HOUSING - UL2108 INSTALLATIONS ONLY

Gain access to wiring compartment. Low flux cover plate is removed by leveraging side tabs to pop off. High flux cover plate is removed by loosening screws "Fig.19".

**Note:** Supplied internal wiring is 18-gauge with 600V-rated insulation.

Feed structured building wires through knockout, secure to corresponding connector "Fig.20" and tighten strain relief.

**Quick connectors** provided for low voltage connection: Red (+) and Black (-) "Fig.20".

**Note:** Ensure wires are firmly secured and not tangled prior to moving to the next step.

Push all wires into housing and reinstall cover plate, ensuring that no wires are pinched by cover.

**Important:** Confirm that housing is still in the preferred position.

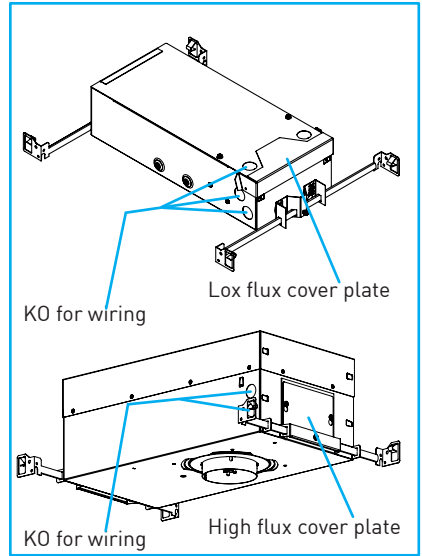

Fig.19

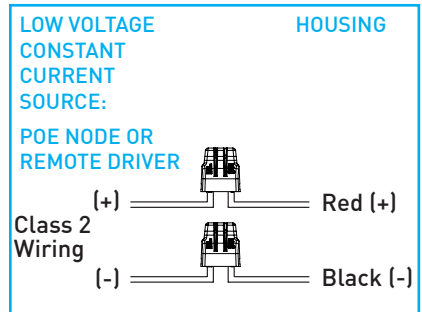





Fig.20

**Drive Current Information:**

	80CA			90CA			97CA			90W
	12L	16L	23H	10L	14L	19H	10L	12L	17H	13H
Minimum Vf	30.5	30.5	30.5	30.5	30.5	30.5	30.5	30.5	30.5	30.5
Maximum Vf	39	39	39	39	39	39	39	39	39	39
Current mA	250	350	500	250	350	500	250	350	500	350
Wattage W	8.2	11.8	17.4	8.2	11.8	17.4	8.2	11.8	17.4	11.8

	10 DEGREE OPTIC		
	80CA12L	90CA10L	97CA10L
Minimum Vf	30.5	30.5	30.5
Maximum Vf	39	39	39
Current mA	350	350	350
Wattage W	11.8	11.8	11.8

**Node Compatibility:**

Manufacturer	Model Number
	NP50-60-C-F-5
	180996-1001 180996-1002 180996-2001 180996-2002
	1 Channel Node, POE-LN2-1U-E 2 Channel Node, POE-LN2-2U-E 4 Channel Node, POE-LN2-4U-E

## E. CEILING SUBSTRATE AND FINISH OUT

### 1. CEILING THICKNESS

Fixtures compatible with .125" (3.2mm) to 3.00" (73mm) ceilings.

### 2. CEILING CUT-OUTS

Factory recommends use of properly sized hole saw for cut-outs. Correct size and quality of hole is critical. Many trims have minimal ceiling overlay of trim flange.

Make proper hole cut-out, referencing measurements from adjacent walls to housing collar / aperture centerline.

#### IC & NON-IC HOUSINGS CUT-OUTS

**3.75" (95mm)** dia. for flange overlay

**5.60" (142mm)** dia. for zero-sightline

#### REMODEL / TETHERED POWER SUPPLY FIXTURE CUT-OUT

**3.625" (92mm)** dia. for all applications

### 3. GEMINI REMODEL

Factory recommends 6.75" (172mm) spacing between remodel fixtures for **GEMINI INSTALLATIONS ONLY** "Fig.21".

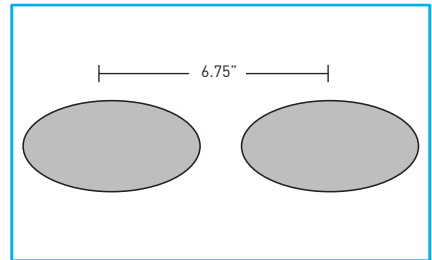

Fig.21

### 4. JA8-2016 TITLE 24 INSTALLATIONS

Once the ceiling is installed, using a caulk suitable for the site conditions and associated materials, apply a bead of caulk between housing collar and ceiling substrate to create an airtight seal, in accordance with CEC instructions and guidelines

"Fig.22" "Fig.23".

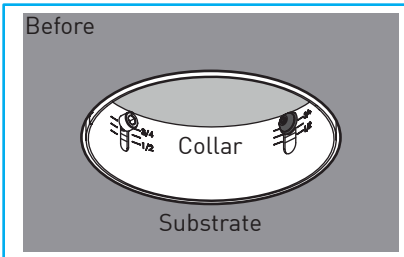

Fig.22

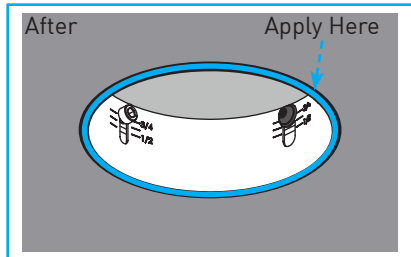

Fig.23

## 5. GYPSUM BOARD

Install drywall in typical fashion. Oversized hole cut-outs must be filled in with mud or plaster, utilizing appropriate tape in accordance with industry standards, prior to trim installation.

**Note:** For zero-sightline drywall installations, see Section H.2.

**Important:** If zero-sightline, appliqué must be installed prior to mudding or finishing of ceiling. Failure to follow these instructions will lead to failed expectations and added expense.

Sand, prime, and apply finish coat to ceiling.

## 6. T-GRID LAY-IN TILE CEILING

Install tiles in accordance with manufacturer's recommendations.

**Note:** See General Housing Mounting Notes in Section D.4.

**Important:** Zero-sightline installations are not compatible with lay-in tile ceiling applications.

**Important:** Remodel installation methods are not suitable for lay-in tile ceiling applications; use housing instead.

## 7. FLANGE OVERLAY WOOD CEILING

Install wood in accordance with local and national building codes, employing suitable fire barriers as required. Hole cut-outs should be clean and precise. Sand, stain and apply finish seal coat prior to installing trim.

## 8. ZERO-SIGHTLINE WOOD CEILING

**Note:** It is recommended to perform the following installation method on a test piece of wood to become familiar with the process and to verify that the plunge router depth is set accurately, prior to proceeding to an actual fixture location.

**Note:** This procedure utilizes DLA-RTG-2S-RD (Round Router Tool Guide) "**Fig.24**", or DLA-RTG-2S-SQ (Square Router Tool Guide) "**Fig.25**".

Locate the center of the fixture and drill a 5/64" (2mm) pilot hole "**Fig.26**".

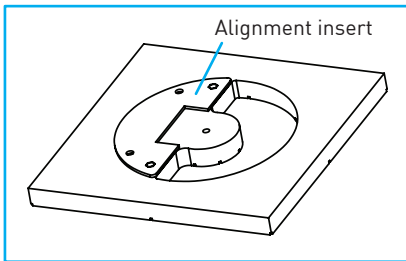

Fig.24

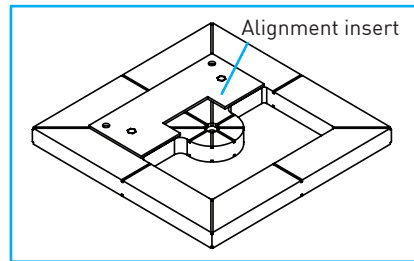

Fig.25

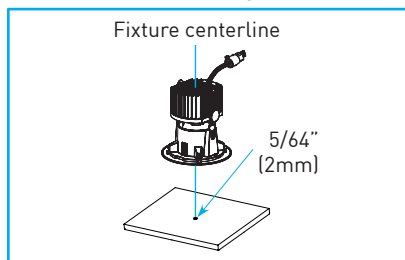

Fig.26

Remove alignment insert from the template using a #1 Phillips head screwdriver, making sure to reserve insert and screws for later step **"Fig.27"**.

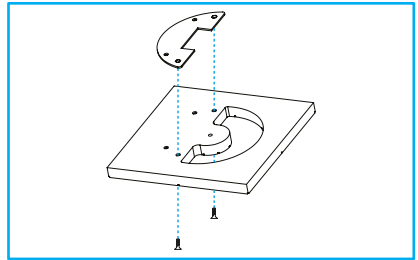

Fig.27

Place the smooth side of the template against the wood surface, aligning the center mounting hole with the pilot hole. Attach template loosely with a #6 wood screw, using alignment grooves to properly position unit **"Fig.28"**.

Tighten center screw and then tighten other two template mounting screws.

**Note:** Hardness of wood may require pilot holes be drilled for template mounting screws, ensuring proper alignment before drilling.

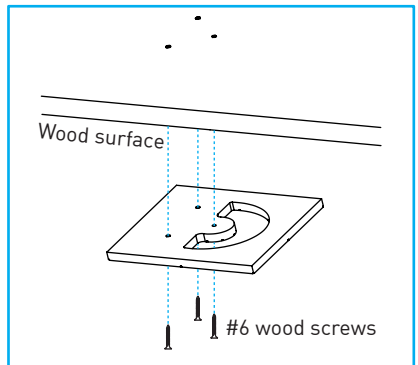

Fig.28

Using plunge router with depth set per test sample, insert into interior portion of template and remove material to required depth, ensuring that the router base is kept level with the template **"Fig.29"**.

Remove template from ceiling.

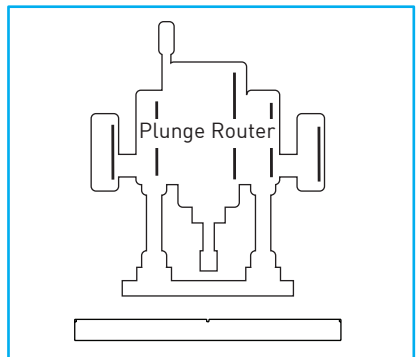

Fig.29

**Note:** For square trim installations, use a sharp utility knife to score wood, forming two square corners. Then, use a sharp wood chisel to remove the remaining material to the same depth **"Fig.30"**.

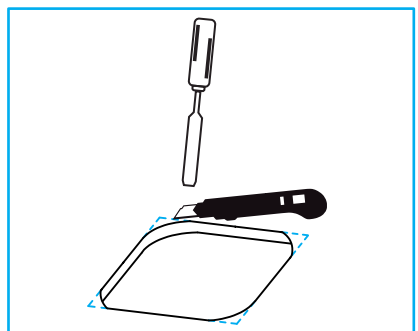

Fig.30

Reattach alignment insert to flat side of template, using reserved screws from prior step **"Fig.31"**.

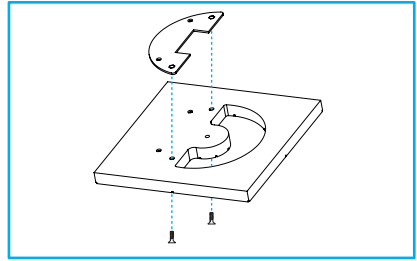

Fig.31

With template rotated 180°, position alignment insert into the dado cut, ensuring that it seats firmly against the outer edge of the primary cut **"Fig.32"**.

Insert center mounting screw and tighten.

Verify alignment and insert remaining template mounting screws.

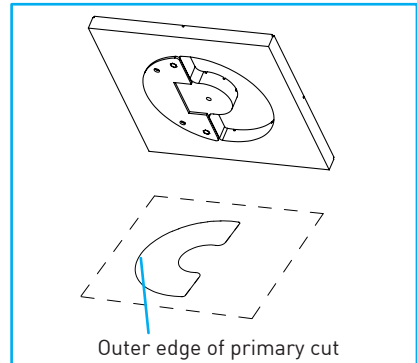

Fig.32

Use plunge router to remove material to required depth, ensuring that the router base is kept level with the template **"Fig.33"**.

Remove template from ceiling.

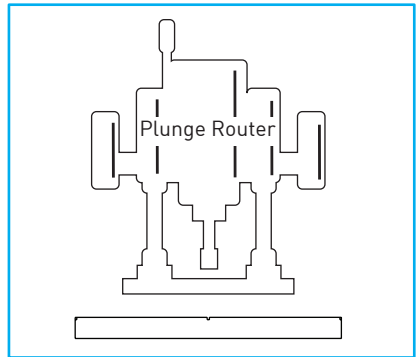

Fig.33

**Note:** For square trim installations, use a sharp utility knife to score wood, forming two square corners. Then, use a sharp wood chisel to remove the remaining material to the same depth **"Fig.34"**.

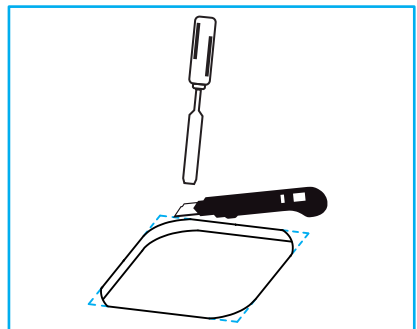

Fig.34

**Note:** Prior to drilling through hole, ensure that dado is cut to sufficient depth.

**Remodel Installations:**

Cut a hole using a 3.625" (92mm) hole saw, centered on the pilot hole **"Fig.35"**.

**Housing Installations:**

Cut a hole using a 3.75" (95mm) hole saw, centered on the pilot hole **"Fig.35"**.

Adjust housing collar down and level with dado cut **"Fig.36"**.

**Note:** With proper care, the template should be suitable for many uses. Replace worn or damaged template to ensure satisfactory installation.

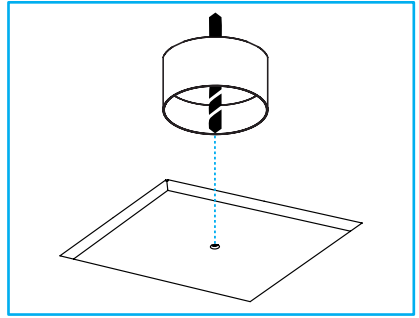

Fig.35

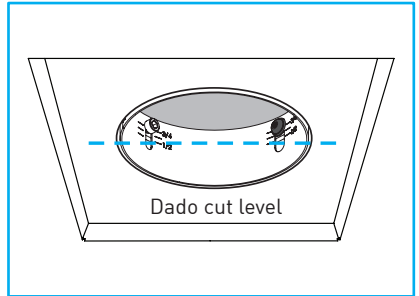

Fig.36



## F. REMODEL APPLICATION

### 1. GENERAL WIRING NOTES

These instructions are for remodel applications only. For housings, see Section C.

During rough-in stage of construction, identify approximate fixture locations. Ensure that sufficient space is available to accommodate factory-required setback and depth allowances (see Section B.10) for respective trim and remodel driver assembly.

Install appropriate conduit and wiring to each predetermined fixture location, in accordance with NEC and local code requirements, ensuring that adequate slack is provided for making connections to fixture from below finished ceiling plane.

Install finished ceiling, see section "E. CEILING SUBSTRATE AND FINISH OUT".

Determine center point of trim location, boring clean and precise cut-out. Be cautious to avoid cutting or nicking wires above, see Section "D. WIRING".

Locate and guide structured wiring / conduit down and through ceiling cutout "**Fig.37**".

**Note:** Reference Section D.4 for UL 2108 wiring connections.

### 2. WIRE / INSTALL REMODEL POWER SUPPLY

Access splice compartment of PS2-RMD remodel power supply by removing retaining screw(s), then tilting cover slightly back and away from base (see Section C.1).

Insert wiring / conduit into splice compartment, utilizing appropriate strain relief or connector.

Join structured building wires to corresponding wires with suitable customer-supplied connecting device.

**Note:** Improper polarity may cause damage to the unit and can void the warranty.

Push all wires and wire connections into splice compartment, and reinstall splice compartment cover by aligning tab and slot, ensuring no wires are pinched by cover. Install retaining screw(s).

Carefully insert finished power supply assembly up through cut-out to rest atop the ceiling, taking care not to damage ceiling plane or cutout "**Fig.38**".

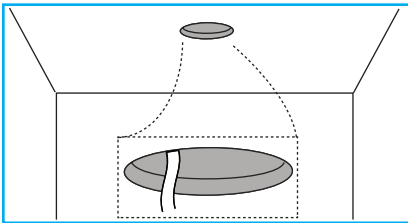

Fig.37

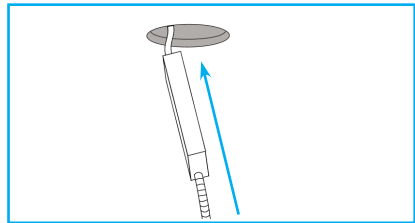

Fig.38

## G. DRIVER INSTALLATION

### 1. DRIVER INSTALLATION

The following instructions assume the housing has been installed with initial alignment completed. For remodel installations, see Section "F. REMODEL APPLICATION"

Consult diagrams in Section "K. WIRING DIAGRAMS", joining corresponding driver and structured wiring using supplied push-in connectors "Fig.39".

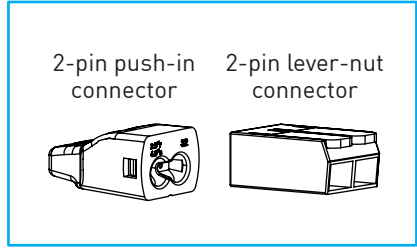

Fig.39

Raise and guide driver assembly through housing aperture, allowing sleeved wires to follow sled "Fig.40".

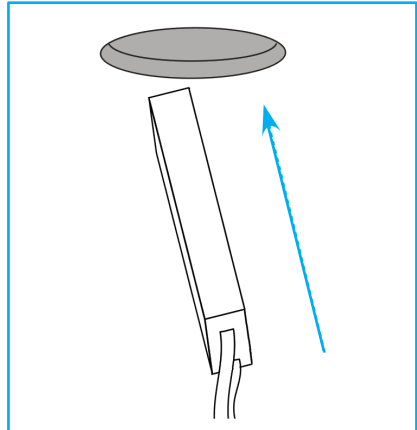
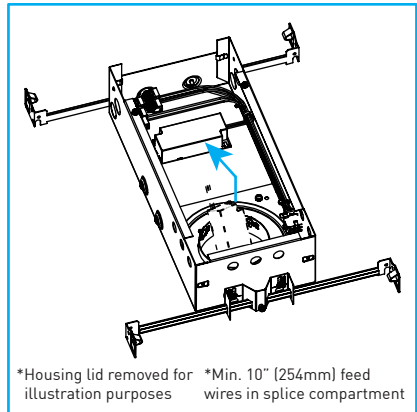

Fig.40

Slide driver to back of housing until Velcro engages. Leave 2-pin lever-lock connectors or hanging through housing collar "Fig.41".

**Note:** At least 10" (254mm) of service loop must be provided in the splice compartment for driver servicing.



\*Housing lid removed for illustration purposes \*Min. 10" [254mm] feed wires in splice compartment

Fig.41

## H. TRIM INSTALLATION

**Important:** Trim adaptor must be removed prior to any refinishing or repainting of ceiling. Presence of paint, ceiling mud or other construction materials on or in adaptor represents unsafe condition, must be replaced or cleaned to original condition and specifications to maintain factory warranty.

### 1. INSTALL TRIM ADAPTOR - FLANGE OVERLAY / ZERO-SIGHTLINE WOOD

Ensure ceiling is finished before beginning trim installation.

Determine direction or wallwashing surface trim is intended to aim at, pointing the blue line on the trim adaptor in that direction "**Fig.42**".

Ensure trim adaptor arms are pointed inward. Insert adaptor up through housing collar or ceiling cut-out as applies "**Fig.43**".

Begin tightening adaptor arm screws, ensuring arms swing out, then down engaging top of housing collar lip or ceiling substrate in remodel applications.

Utilize string line or laser level to obtain uniform or desired alignment between multiple fixtures and square fixtures in relation to parallel planes referencing markings on trim adaptor face perimeter "**Fig.44**".

Hand-tighten adaptor arm screws, not exceeding 5 in.-lbs. (0.565 Nm), ensuring adaptor lip seats uniformly flush with finished ceiling plane and housing collar "**Fig.45**".

Guide low-voltage wiring and safety lanyard through adaptor to hang below ceiling to facilitate trim installation "**Fig.46**".

*Connector type varies and may look different than graphic.*

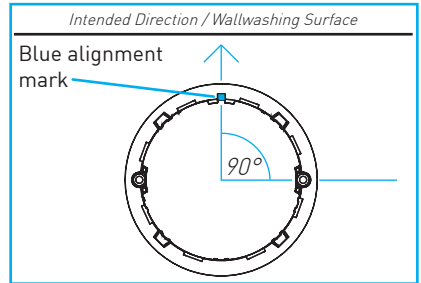

Fig.42

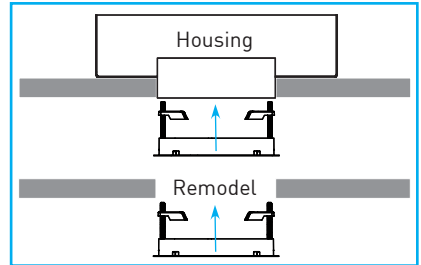

Fig.43

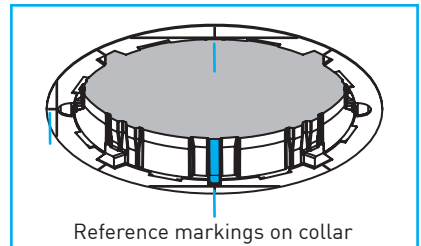

Fig.44

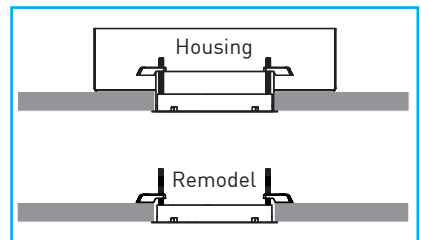

Fig.45

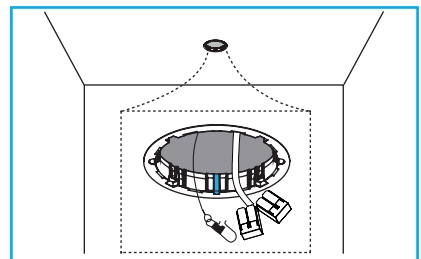

Fig.46

## 2. INSTALL APPLIQUÉ AND TRIM ADAPTOR - ZERO-SIGHTLINE DRYWALL

An appliqué is required for zero-sightline installations. The following instructions assume housing has been installed and / or proper ceiling cut-out has been made ready to accept appliqué and / or trim adaptor.

**Important:** For square fixture installations, appliqué must be properly aligned. Utilize string line or laser level to obtain uniform or desired alignment between multiple fixtures, or in relation to parallel planes **"Fig.47"**.

**With Housing:** For installations utilizing a downlight housing, align 4 countersunk screw holes in appliqué with corresponding holes of rotatable housing collar in ceiling cut-out. Use 4 provided screws through proper holes in appliqué and tighten until appliqué is fully seated against ceiling surface **"Fig.48"**, ensuring desired alignment if square appliqué is used.

**Without Housing:** For remodel or tethered power supply installations without a housing, center appliqué in cut-out and install trim adaptor (with arms pointed inward) up through appliqué. To secure, tighten adaptor screws so arms swing out then down, until appliqué is fully seated against ceiling surface **"Fig.49"**, ensuring desired alignment if square appliqué is used.

Trim adaptor should rest completely and uniformly in appliqué recess.

**Important:** After plaster mudding / floating has been performed, subsequent appliqué adjustment is not possible. Ensure proper, fully seated fit and desired alignment if square.

After appliqué is secured (by screws or trim adaptor), install plaster plug **"Fig.50"**.

Do not remove plug until all plaster and paint work is complete.

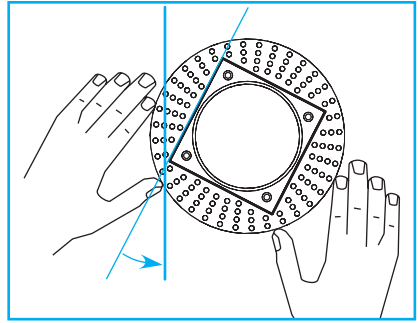

Fig.47

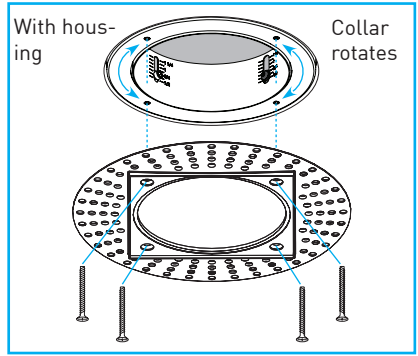

Fig.48

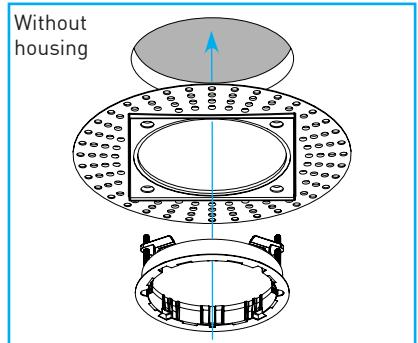

Fig.49

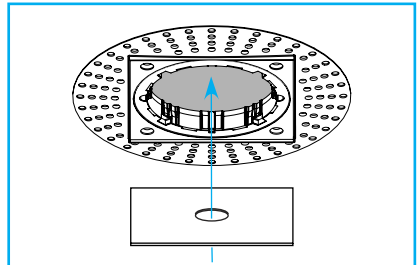

Fig.50

With paint / plaster plug installed, **"Fig.51"** use floating knife to apply first pass of drywall compound and float area up to slightly below edge of flange / plaster stop. Float out as far as necessary to hide perforated appliqué and allow first pass of joint compound to dry **"Fig.52"**.

After first pass is dry, apply second coat of drywall compound. Make surface as smooth as possible. Ensure coat of compound falls below flange / plaster stop **"Fig.53"**.

On final pass, feather compound as you move away from flange to give appearance of a perfectly flat ceiling **"Fig.54"**. Allow drywall compound to dry fully and cure.

Gently use block sanding screen and sand surface until drywall compound is even with bottom of flange / plaster stop **"Fig.55"**. Ensure surface is smooth.

Apply primer and paint as required. After paint is dry, remove plaster plug making sure adhesive tape is removed as well.

Check for any drywall compound or paint that may have seeped beneath plug and carefully scrape if necessary.

**Important:** Any foreign material left in or on recessed appliqué surface or trim adaptor may prevent proper fixture installation and satisfactory zero-sightline trim installation.

**Note:** The size of some power supplies may require removal of trim adaptor to facilitate insertion through cut-out.

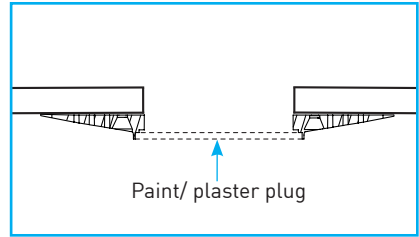

Fig.51

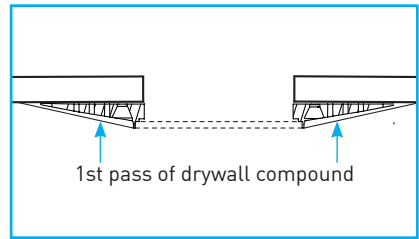

Fig.52

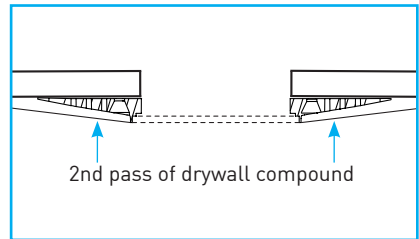

Fig.53

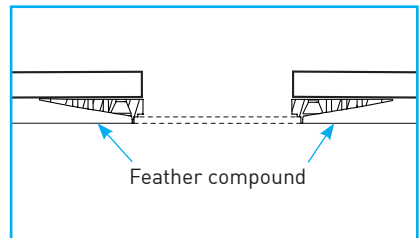

Fig.54

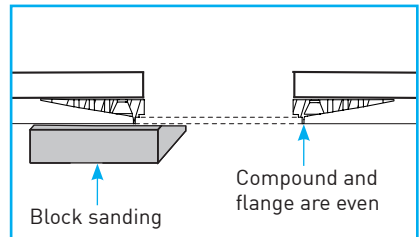

Fig.55

### 3. INSTALL TRIM - ALL APPLICATIONS

Attach safety lanyard from mounting adaptor to designated hole in support arm of downlight fixture using supplied clasp.

Attach LED wiring to the corresponding 2-pin lever-nut connectors. Red to Red (+), Black to Black or Blue (-) **"Fig.56"**.

*Connector type varies and may look different than graphic.*

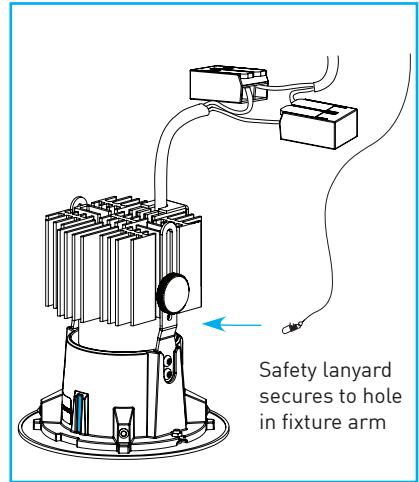

Fig.56

LED downlight fixtures typically accept multiple effects devices.

To install, change, or rearrange reflector or effects devices, loosen thumb screws of fixture, then slide LED engine assembly up and swing out for access "**Fig.57**".

To change reflector, carefully grab and twist counter-clockwise to remove and clockwise to secure.

Position required special effects device(s) in lens recess of downlight in preferred order and correct orientation.

Return LED engine assembly to locking position and secure by tightening thumb screws.

**Important:** Before final downlight installation in ceiling, ensure LED engine assembly is secure and safety lanyard is properly affixed to downlight and mounting adaptor.

Downlight trim mates with housing / ceiling collar via positive engagement, high performance ball-plungers.

To install downlight, ensure blue line of trim is aligned with blue line of trim ceiling adaptor, guide safety lanyard and power supply wires up through opening so that they do not become entangled or pinched and insert trim up into neck of adaptor.

Apply even pressure to underside of trim faceplate (mechanism, if adjustable trim) until the unit "pops" up into final resting position in adaptor "**Fig.58**".

Verify trim faceplate seats fully and uniformly flush to ceiling plane "**Fig.59**".

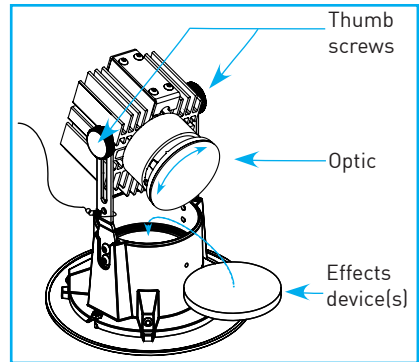

Fig.57

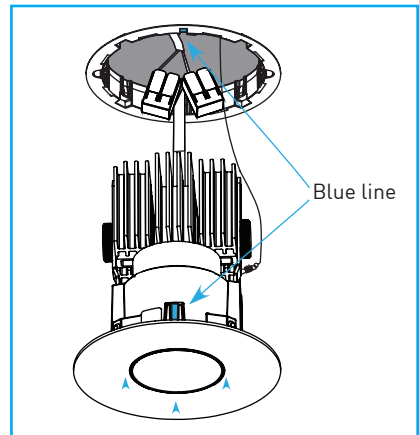

Fig.58

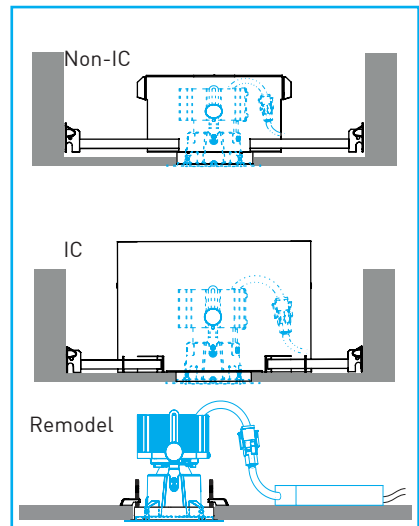
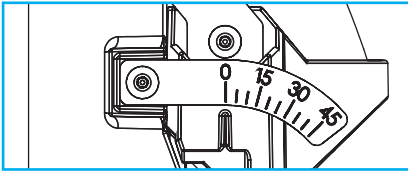

Fig.59

## I. ADJUSTABLE FIXTURES

Hot-aim tilt and rotation adjustment is accessed by removing fixture's faceplate held in place by rare earth magnets, revealing adjustment mechanisms "Fig.60".

Initial adjustment to fixture tilt may be made prior to installing downlight by using marked indicator.



Spring loaded tilt allows fixture to pass through ceiling opening in vertical position and return to pre-set angle once installed.

Adjustments made with supplied, standard .050" Allen tool.

With faceplate removed, locate tilt adjustment screw and rotation lock screw.

### 1. ROTATION

To rotate, use supplied hex tool and loosen lock screw, then carefully set trim to desired position by hand. Tighten lock screw to secure "Fig.61". **DO NOT OVER TIGHTEN.**

### 2. TILT

To adjust tilt, use hex tool with countersunk jack screw and rotate counter-clockwise to increase tilt angle (up to 45° max), or clockwise to decrease tilt angle "Fig.62".

**DO NOT TURN SCREW PAST LIMITS OF ADJUSTMENT, DAMAGE TO MECHANISM MAY ARISE.**

Complete installation by bringing faceplate close to mechanism, aligning magnets, and allow faceplate to seat to trim and ceiling plane.

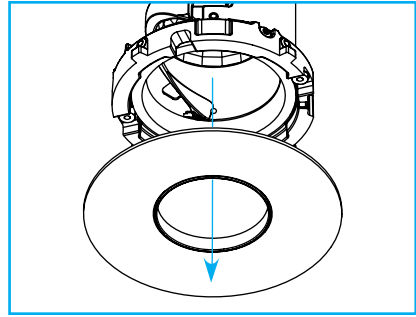

Fig.60

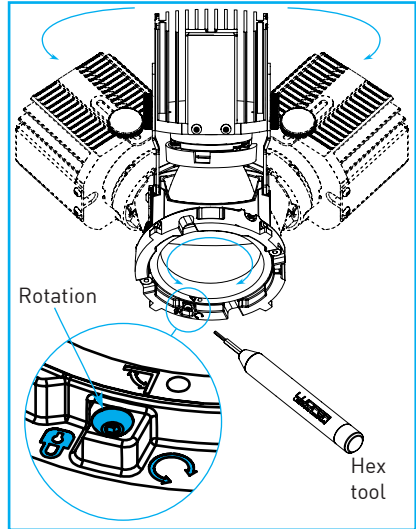

Fig.61

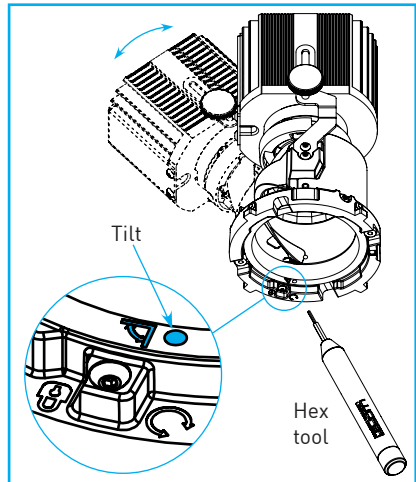

Fig.62



## J. SERVICING

**Important:** Before servicing or maintaining trim or housing, disconnect electrical power at main switch or circuit breaker. Additionally, heed all WARNINGS and CAUTIONS, review the Safety Instructions, and refer to figures in main installation instructions where necessary.

### 1. REPLACING LED ENGINE ASSEMBLY:

A. Remove trim from ceiling using following techniques for the respective trim type.

- Fixed Trims – Using round-shafted flat blade screw driver, carefully position blade of screw driver on top of baffle with shaft gently resting on opposing trim aperture. Pry slightly to dislodge trim from trim adaptor.
- Wallwash Trims – Grasp baffle using soft gloves or with clean soft cloth, pulling away from mounting plane.
- Adjustable Trims:
  1. Dry / Damp – Insert fingers in trim aperture, grabbing and pulling downward on removable faceplate.
  2. Wet – Carefully grasp perimeter of trim pulling downward on removable faceplate.
  3. With respective faceplate removed, grasp trim mechanism with fingers and pull downward.

B. Release trim from wiring harness by disconnecting male / female connectors, or releasing trim wiring from 2-pin lever-nut connectors.

C. Detach LED Engine assembly by loosening and removing two knurled knob thumb screws. Save thumb screws **"Fig.63"**.

D. Replace with new OEM LED engine assembly sourced through Lucifer Lighting, reversing order of preceding steps. IC and Non-IC replacement LED engines will be provided with 2-pin lever-nut connectors.

E. Reinstall the trim in the trim adapter.

### 2. EXCHANGING EFFECTS DEVICE OR OPTIC

A. To begin installing, changing, or rearranging optic or effects devices, remove the trim from the trim adapter.

To change effects device, loosen thumb screws of fixture, then slide LED engine assembly up and swing out for access **"Fig.63"**.

B. To change optic, carefully grab and twist counter-clockwise to remove and clockwise to secure. Ensure that both feet of optic properly engage LED base **"Fig.63"**.

C. Reinstall the trim in the trim adapter.

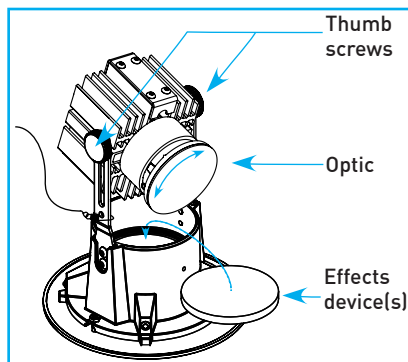

Fig.63

### 3. DRIVER REPLACEMENT

A. Replace driver using following techniques for the respective installation type:

#### 1. IC / NIC Installations

- Driver assembly is accessed through housing aperture. With trim removed, insert hand through housing opening, grasping sleeved wires and pulling outward to release driver sled assembly from Velcro.
- Rotate driver sled assembly as required to facilitate guiding down and through ceiling opening.
- Disconnect quick-connectors to free sled from housing.
- Replace with OEM driver assembly sourced through Lucifer Lighting.
- Connect driver wiring to 2-pin push-in connectors in housing, returning driver sled back through housing opening.
- Ensure that wires are correctly placed and rest driver sled on bottom surface of housing.
- Slide sled assembly into housing, pressing firmly until Velcro engages to retain sled in place **"Fig.64"**.

#### 2. Remodel

- Pull wiring harness to guide remodel power supply through opening.
- Open power supply assembly by removing retaining Phillips screw.
- Disconnect line voltage wiring and remove power supply assembly from conduit or wiring.
- Replace with new OEM power supply assembly sourced through Lucifer Lighting.
- Reconnect proper strain relief or conduit to power supply assembly and terminate wires with suitable splice connections in accordance with standard practices.

B. Reinstall the trim in the trim adapter.

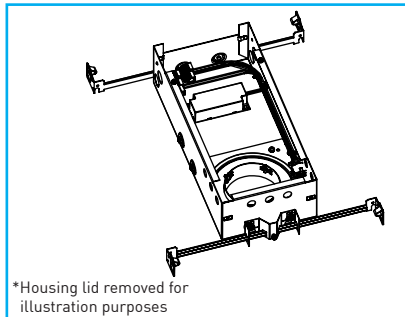

Fig.64

### 4. FIELD PAINTING OF TRIM:

Though we strongly recommend custom paint be applied by factory during manufacturing, trims may be field painted without impacting factory mechanical warranty using following guidelines.

- Select paint suitable for application and location of trim, recognizing Lucifer Lighting Company fixtures are tested not to exceed temperatures of 90° Celsius, where typical operating temperature of faceplate is 46° Celsius nominal.
- Trim plate surface must be properly prepped in accordance with paint manufacturer's instructions. Paint supplied and furnished by customer.

**Important:** Paint to be applied to trim faceplate only. Do not apply paint to magnets of adjustable series trim. Any disassembly or modification to trim or mechanism voids factory warranty and may represent an unsafe operating condition.

## K. WIRING DIAGRAMS

### GENERAL WIRING NOTES

1. Consult approved dimmer list to ensure compatibility.
2. Install in accordance with manufacturer's dimmer installation guidelines.
3. Secondary and 0-10V connections are polarity sensitive.

### WIRING DIAGRAM FOR LINE DIMMING

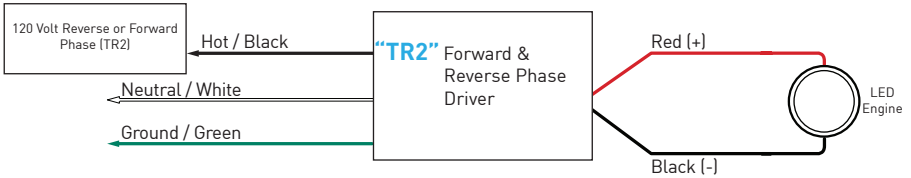

### WIRING DIAGRAM FOR ANALOG CONTROL

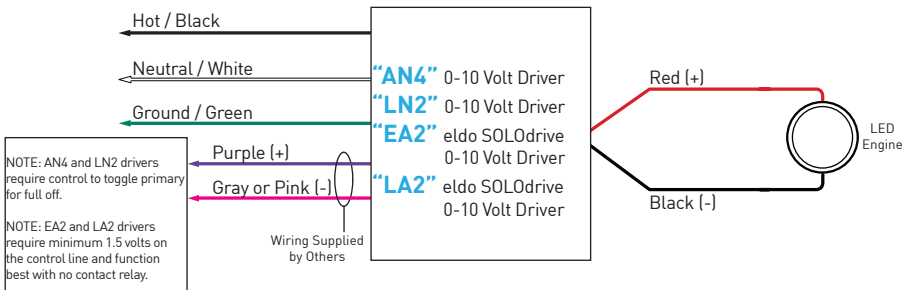

### WIRING DIAGRAM FOR ECOSYSTEM AND DIGITAL CONTROL

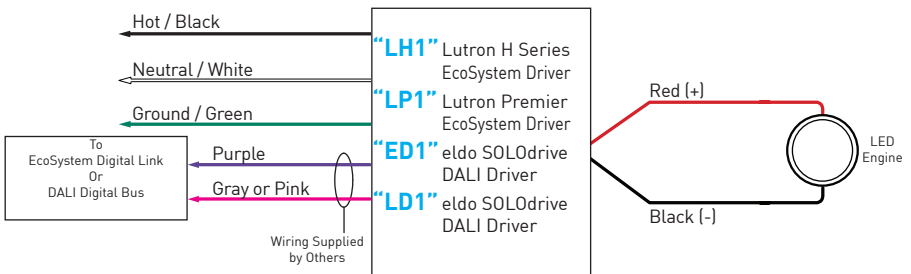

## WIRING DIAGRAM FOR TUNABLE WHITE ANALOG CONTROL

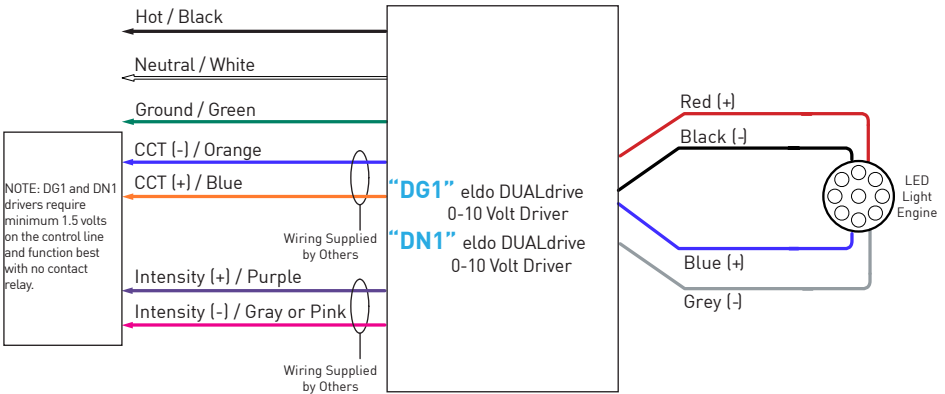

## WIRING DIAGRAM FOR TUNABLE WHITE DALI CONTROL

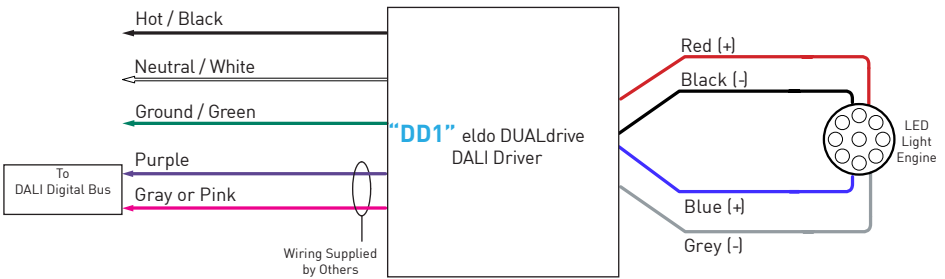

## REMOTE DRIVER WIRING DISTANCE

### Lutron Drivers: "LP1"

AWG Value	18	16	14	12
Distance (ft)	15	25	40	60
Distance (m)	4.5	7.5	12	18

### eldoLED Drivers: "ED1", "EG1", "EN1", "DD1", "DG1" & "DN1"

AWG Value	20	18	16
Distance (ft)	46	72	118
Distance (m)	14	22	36

Please consult website for full warranty terms and conditions:

[www.luciferlighting.com/warranty](http://www.luciferlighting.com/warranty)

[09202024]

3750 North PanAm Expressway  
 San Antonio, TX 78219 USA  
 [PH] +1 210 227 7329  
 [FAX] +1 210 227 4967  
[www.luciferlighting.com](http://www.luciferlighting.com)

**LUCIFER**®  
 LIGHTING COMPANY

©2024 Lucifer Lighting Company  
 As part of its policy of continuous research and product development, the Company reserves the right to change or withdraw specifications without prior notice.